

Dell PowerEdge
C6105

Getting Started With Your System



Dell PowerEdge
C6105

**Getting Started
With Your System**

Notes, Cautions, and Warnings



NOTE: A NOTE indicates important information that helps you make better use of your computer.



CAUTION: A CAUTION indicates potential damage to hardware or loss of data if instructions are not followed.



WARNING: A WARNING indicates a potential for property damage, personal injury, or death.

Information in this document is subject to change without notice.

© 2014 Dell Inc. All rights reserved.

Reproduction of these materials in any manner whatsoever without the written permission of Dell Inc. is strictly forbidden.

Trademarks used in this text: Dell™, the DELL logo, and PowerEdge™ are trademarks of Dell Inc. AMD® is a registered trademark and AMD Opteron™ is a trademark of Advanced Micro Devices, Inc. Red Hat Enterprise Linux® and Enterprise Linux® are registered trademarks of Red Hat, Inc. in the United States and/or other countries. Novell® is a registered trademark and SUSE™ is a trademark of Novell Inc. in the United States and other countries. Citrix® and XenServer® are either registered trademarks or trademarks of Citrix Systems, Inc. in the United States and/or other countries. VMware® is a registered trademarks or trademarks of VMWare, Inc. in the United States or other countries.

Other trademarks and trade names may be used in this publication to refer to either the entities claiming the marks and names or their products. Dell Inc. disclaims any proprietary interest in trademarks and trade names other than its own.

Regulatory Model B03S

January 2014

P/N 45F0M

Rev. A06



CAUTION: Restricted Access Location

This server is intended for installation only in restricted access locations as defined in Cl. 1.2.7.3 of IEC 60950-1: 2001 where both these conditions apply:

- Access can only be gained by service persons or by users who have been instructed about the reasons for the restrictions applied to the location and about any precautions that shall be taken.
- Access is through the use of a tool or lock and key, or other means of security, and is controlled by the authority responsible for the location.

Installation and Configuration



WARNING: Before performing the following procedure, review and follow the safety instructions that came with the system.

Unpacking the System

Unpack your system and identify each item.

Installing the Tool-Less Rail Solution



WARNING: Whenever you need to lift the system, get others to assist you. To avoid injury, do not attempt to lift the system by yourself.



WARNING: The system is not fixed to the rack or mounted on the rails. To avoid personal injury or damage to the system, you must adequately support the system during installation and removal.



WARNING: To avoid a potential electrical shock hazard, a third wire safety grounding conductor is necessary for the rack installation. The rack equipment must provide sufficient airflow to the system to maintain proper cooling.



CAUTION: When installing rails in a square-hole rack it is important to ensure that the square peg slides through the square holes.

- 1 Align the end pieces of the rails on the vertical rack flanges to seat the pegs in the bottom hole of the first U and the top hole of the second U. Engage the back end of the rails until the latches lock in place.



 **NOTE:** The rails can be used in both square-hole (item 1 in the following figure) and round-hole racks (item 2 in the following figure).

Figure 1. Pushing the Latch Release Buttons

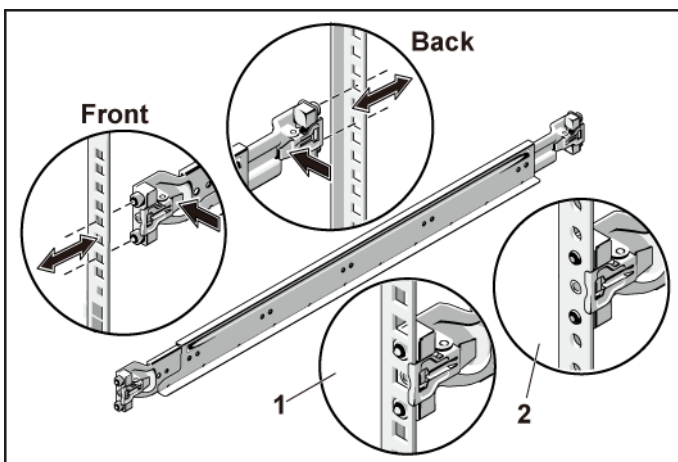

- 2 Repeat Step 1 to position and seat the front end pieces on the vertical flanges.

 **NOTE:** To remove the rails, pull on the latch release button on the end piece midpoint and unseat each rail.

- 3 Slide the system into the rack.
- 4 If present, remove the chassis stabilizer shipping bracket (optional) from the rack.

 **NOTE:** To transport systems already installed in the rack, ensure that the two chassis stabilizer shipping brackets (optional) are in place.

Figure 2. Installing the Chassis Stabilizer Shipping Brackets



- 5 Tighten the thumbscrews to secure the ears of the system to the front of the rack flanges.

Figure 3. Installing the Chassis onto the Rack.

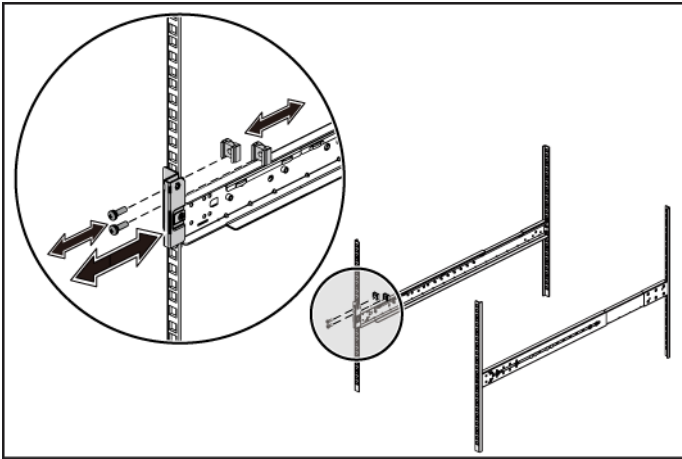
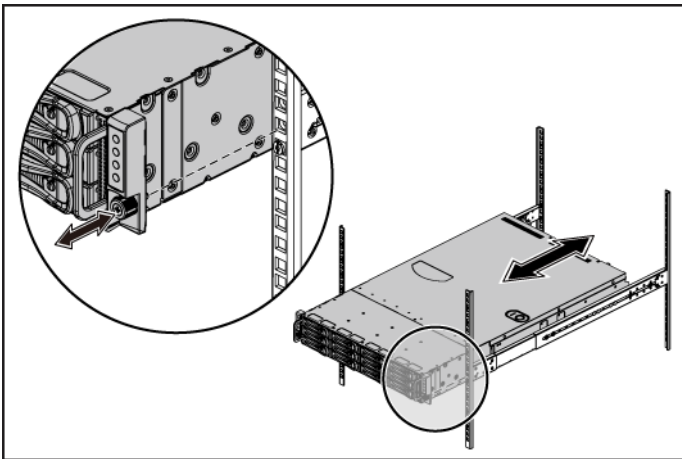

Optional-Connecting the Keyboard, Mouse, and Monitor

Figure 4. Optional—Connecting the Keyboard, Mouse and Monitor

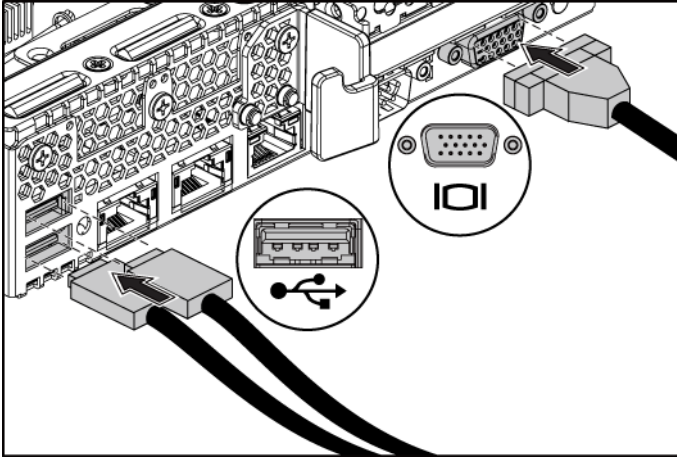

Connect the keyboard, mouse, and monitor (optional).

The connectors on the back of your system have icons indicating which cable to plug into each connector. Be sure to tighten the screws (if any) on the monitor's cable connector.

Connecting the Power Cable(s)

Figure 5. Connecting the Power Cable

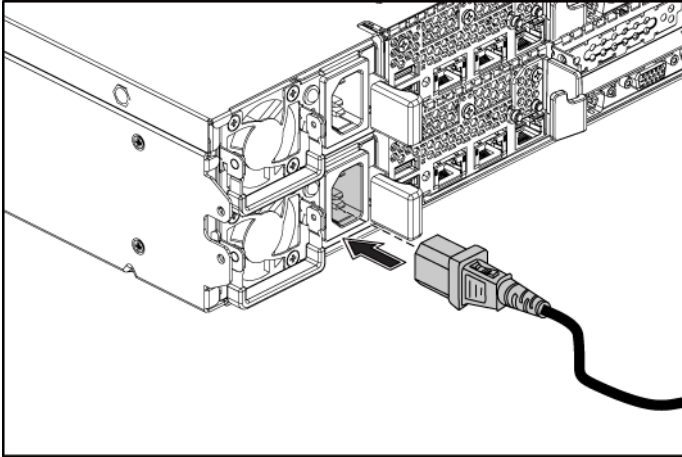

Connect the system's power cable(s) to the system and, if a monitor is used, connect the monitor's power cable to the monitor. Plug the other end of the power cables into a grounded electrical outlet or a separate power source such as an uninterruptible power supply or a power distribution unit.

Turning on the System

Figure 6. Pressing the Power Button on the Front of the System and the Monitor

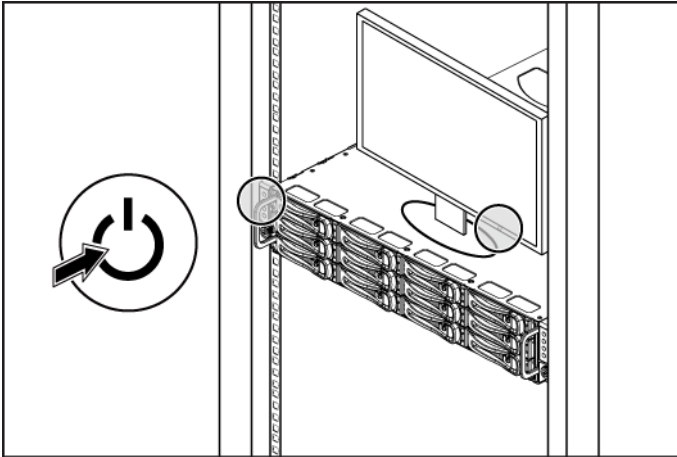
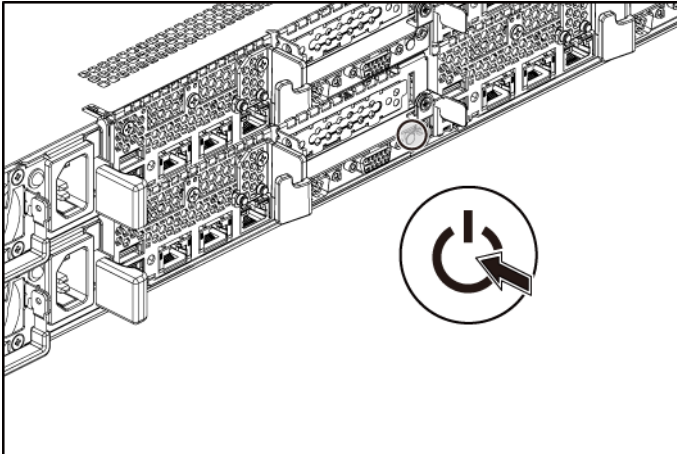

Figure 7. Pressing the Power Button on the Back of the System



Press the power button(s) either on the front or back of the system and on the monitor. The power indicators should light.

Complete the Operating System Setup

To install an operating system for the first time, see the installation and configuration documentation for your operating system. Be sure the operating system is installed before installing hardware or software not purchased with the system.



NOTE: For the latest information on supported operating systems, see [dell.com/ossupport](https://support.dell.com/ossupport).

Other Information You May Need



WARNING: See the safety and regulatory information that shipped with your system. Warranty information may be included within this document or as a separate document.

The *Hardware Owner's Manual* provides information about system features and describes how to troubleshoot the system and install or replace system components. This document is available at support.dell.com/manuals.

Dell systems management application documentation provides information about installing and using the systems management software. This document is available online at support.dell.com/manuals.



NOTE: Always check for updates on support.dell.com/manuals and read the updates first because they often supersede information in other documents.

NOM Information (Mexico Only)

The following information is provided on the device described in this document in compliance with the requirements of the official Mexican standards (NOM):

Importer	Dell Inc. de México, S.A. de C.V. Paseo de la Reforma 2620-11° Piso Col. Lomas Atlas 11950 México, D.F.
Model number	B03S
Supply voltage	100-240 V AC with 470 W/750 W/1100 W Power 200-240 V AC with 1400 W Power
Frequency	50/60 Hz
Current consumption	6.5-3.5 Amps with 470 W Power 8.6 Amps with 1400 W Power 9.5-5.0 Amps with 750 W Power 12-6.7 Amps with 1100 W Power

Technical Specifications

Processor (Per System Board)

Processor type	One or two AMD C32 Series processors One or two AMD Opteron 4000 Series processors One or two AMD Opteron 4200 Series processors One or two AMD Opteron 4300 Series processors
----------------	---

Expansion Bus (Per System Board)

Bus type	PCI Express Generation 2
Expansion slots	
PCIe	One x16, half-length, half-height
Daughter card PCIe	One x8, custom slot

Memory (Per System Board)

Architecture	12 x DDR3 800/1066/1333/1600* MHz registered memory modules with /ECC
Memory module sockets	12 x DDR3 DIMM sockets
Memory module capacities	2 GB, 4 GB, 8 GB, or 16 GB
Minimum RAM	12 GB
Maximum RAM	192 GB



NOTE: System memory working frequency is up to 1333MT/s only.

Drives

Hard drives	Up to twelve 3.5-inch, hot-swappable SAS/SATA drives or up to twenty four 2.5-inch, hot-swappable SAS/SATA/SSD drives NOTE: SAS hard drives are supported by add-on card.
-------------	---

Connectors (Per System Board)

Back

NIC	Two RJ-45 (10/100/1000 Mbps Ethernet)
Serial	9-pin, DTE, 16550-compatible
USB	Two 4-pin, USB 2.0-compliant
Video	15-pin D-Sub VGA
Management port	Dedicated Ethernet port for remote management access

Video (Per System Board)

Video type	On-board AST2050 video controller or AST1100
Video memory	8 MB

Power

AC power supply (per power supply)

Wattage	470 W
Voltage	100-240 VAC, 50-60 Hz, input current range: 6.5-3.5 Amps
Heat dissipation	2390 BTU/hr maximum
Wattage	750 W
Voltage	100-240 VAC, 50-60 Hz, input current range: 9.5-5.0 Amps
Heat dissipation	3414 BTU/hr maximum
Wattage	1023 W low line/1100W high line
Voltage	100-240 VAC, 50-60 Hz, input current range: 12.0-6.7 Amps
Heat dissipation	4575 BTU/hr maximum
Wattage	1400 W
Voltage	200-240 VAC, 50-60 Hz, maximum input current: 9.6 Amps
Heat dissipation	5432 BTU/hr maximum

Maximum inrush current Initial In-rush Current cannot exceed 55 Amps (peak). Secondary In-rush Current cannot exceed 35 Amps (peak).

Battery (per system board)

System battery CR 2032 3.0-V lithium ion coin cell

RAID battery (optional) 3.7-V lithium ion battery pack

Physical

Height 8.76 cm (3.45 in)
Width 44.8 cm (17.6 in)
Depth 75.1 cm (29.47 in)
Weight (maximum configuration) 33.67 kg (74.2 lb)
Weight (empty) 15.11 kg (33.32 lb)

Environmental

NOTE: For additional information about environmental measurements for specific system configurations, see www.dell.com/environmental_datasheets.

Temperature

Operating 10° to 35°C (50° to 95°F) with a maximum temperature gradation of 10°C per hour

NOTE: For altitudes above 2950 feet, the maximum operating temperature is derated 1°F/550 ft.

Storage -40° to 65°C (-40° to 149°F) with a maximum temperature gradation of 20°C per hour

Relative humidity

Operating 20% to 80% (noncondensing) with a maximum humidity gradation of 10% per hour

Storage 5% to 90% (noncondensing)

Maximum vibration

Operating 0.26 Grms at 5–350 Hz

Storage 1.88 Grms at 10–500 Hz for 15 min

Maximum shock

Operating	One shock pulse in the positive z axis (one pulse on each side of the system) of 31 G for 2.6 ms in the operational orientation
Storage	Six consecutively executed shock pulses in the positive and negative x, y, and z axes (one pulse on each side of the system) of 71 G for up to 2 ms; Six consecutively executed shock pulses in the positive and negative x, y, and z axes (one pulse on each side of the system) of 27 G faired square wave pulse with velocity change at 235 inches/second (597 centimeters/second)
Altitude	
Operating	–16 to 3,048 m (–50 to 10,000 ft) NOTE: For altitudes above 2950 feet, the maximum operating temperature is derated 1°F/550 ft.
Storage	–16 to 10,600 m (–50 to 35,000 ft)
Airborne contaminant level	
Class	G2 or lower as defined by ISA-S71.04-1985



Printed in the U.S.A.

www.dell.com |



45 F 0 MA 06